

BISON 35 OTI

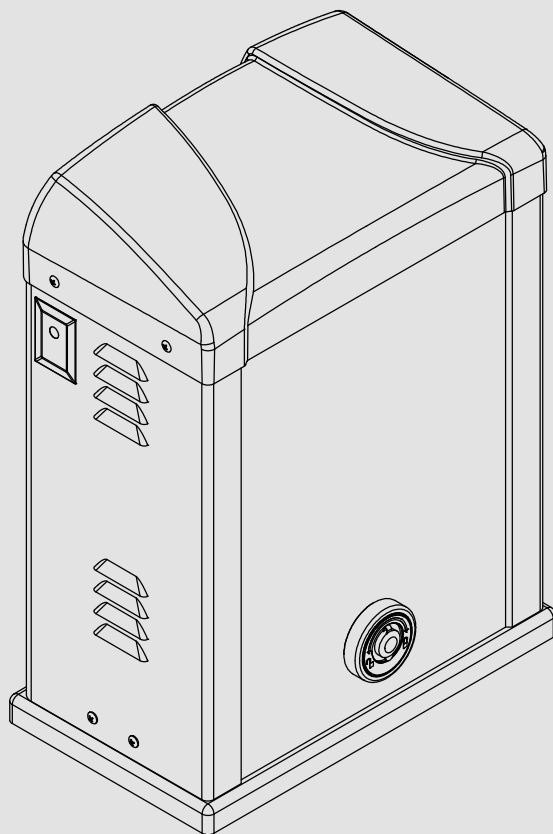

BENINCA[®]
TECHNOLOGY TO OPEN

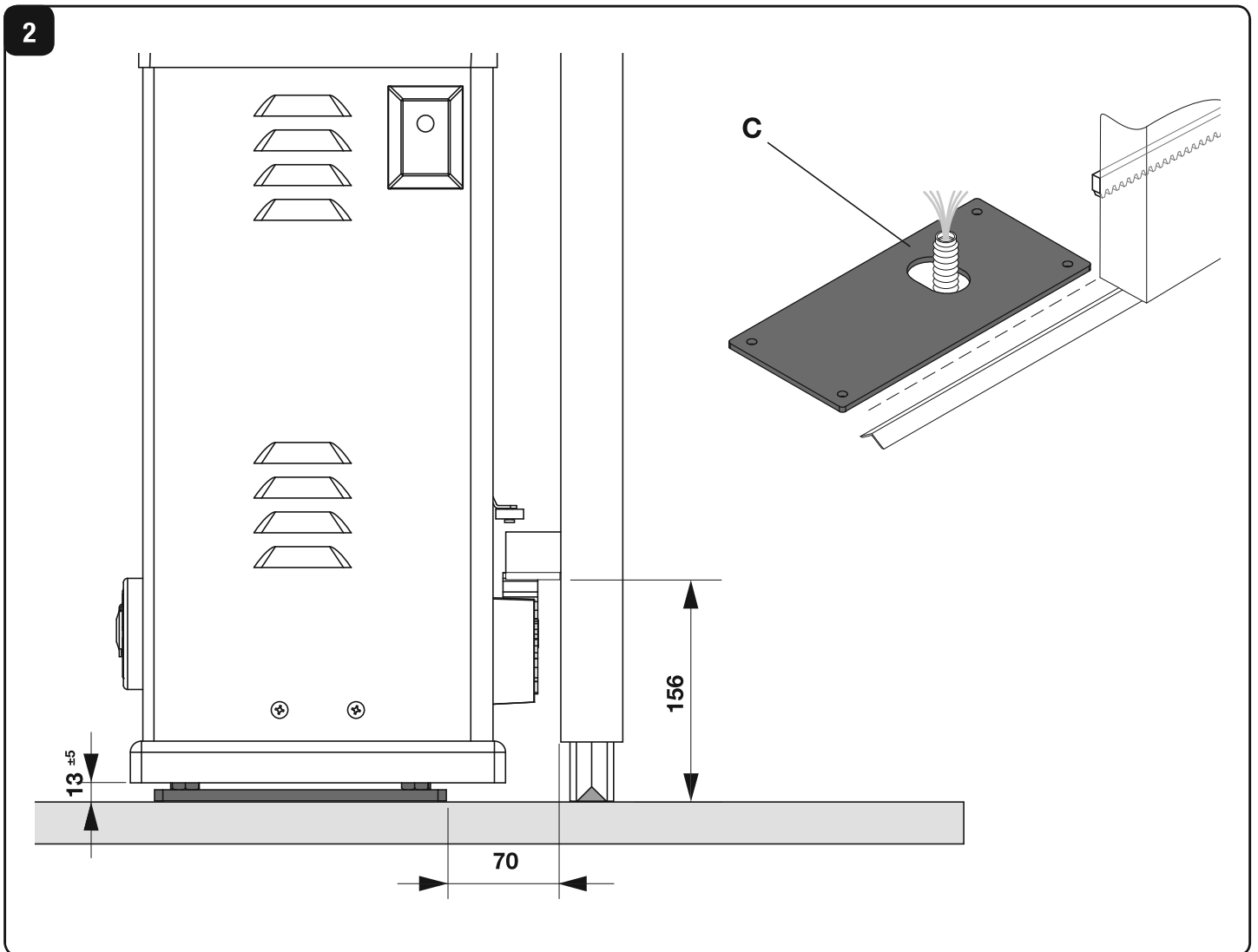

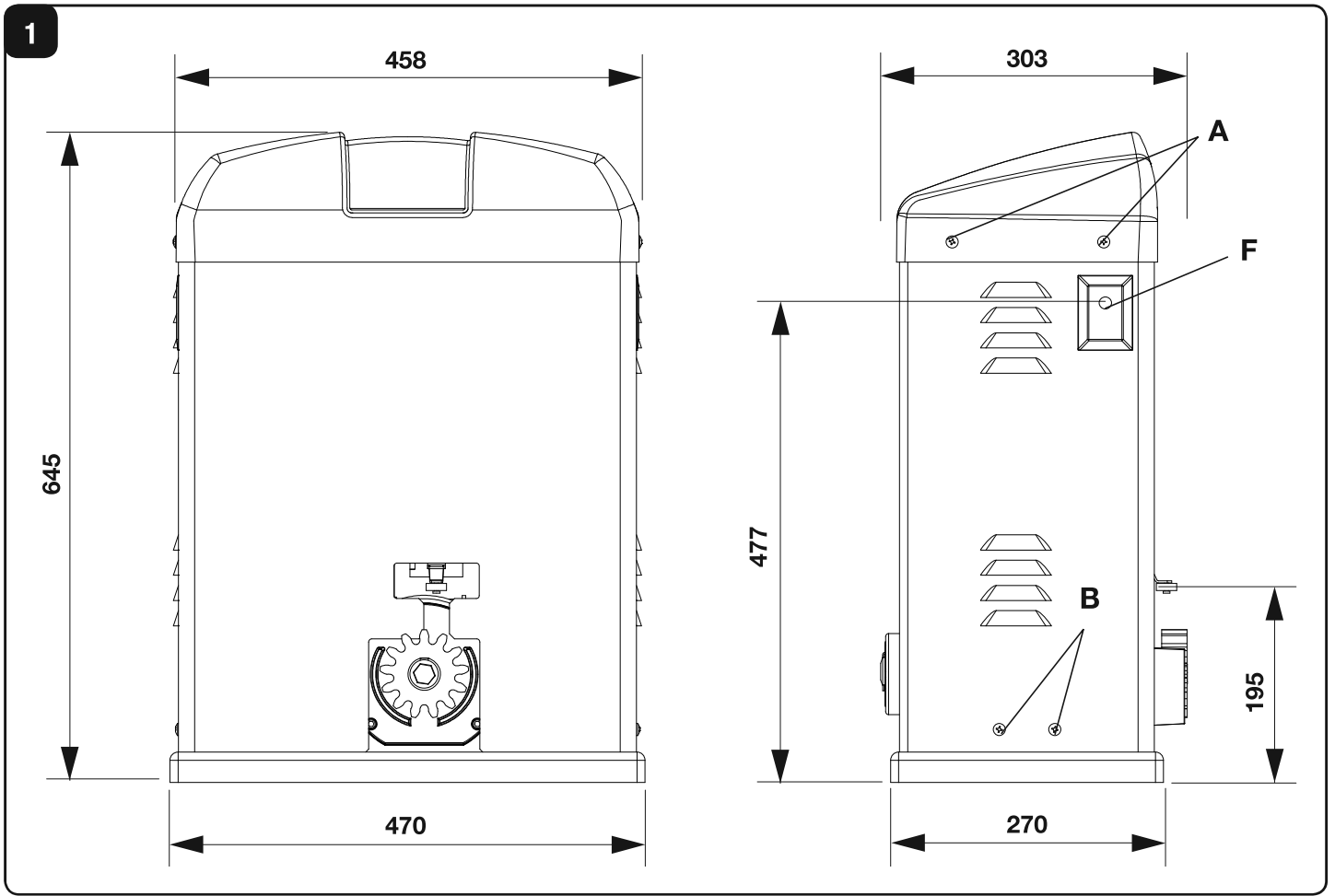

3

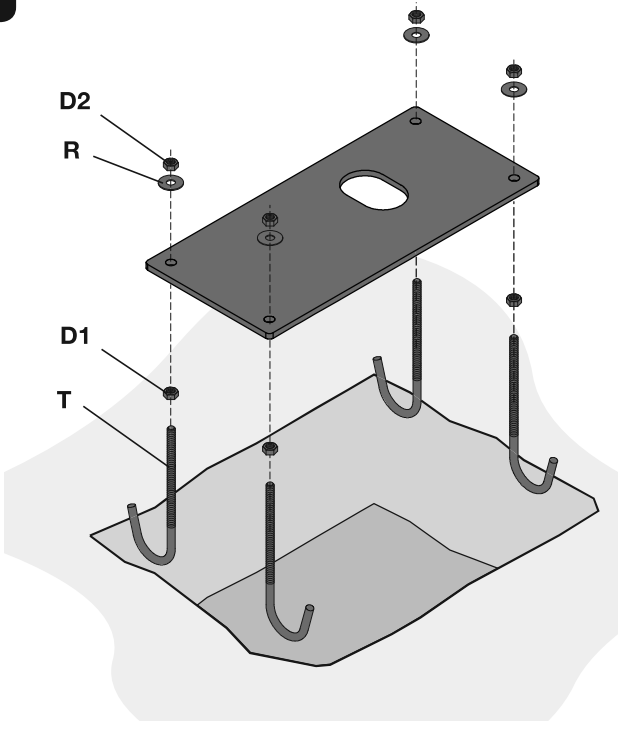

Accessorio piastra BISON.P35 (cod. 9623066) non incluso
Accessory plate BISON.P35 (cod. 9623066) not included
 Zubehör Fundamentplatte BISON.P35 (kode 9623066) nicht enthalten
Accessoire plaque BISON.P35 (cod. 9623066) non compris
 Accesorio placa BISON.P35 (cod. 9623066) no incluido
Nie zawiera płyty podstawy BISON.P35 (kod 9623066)

4

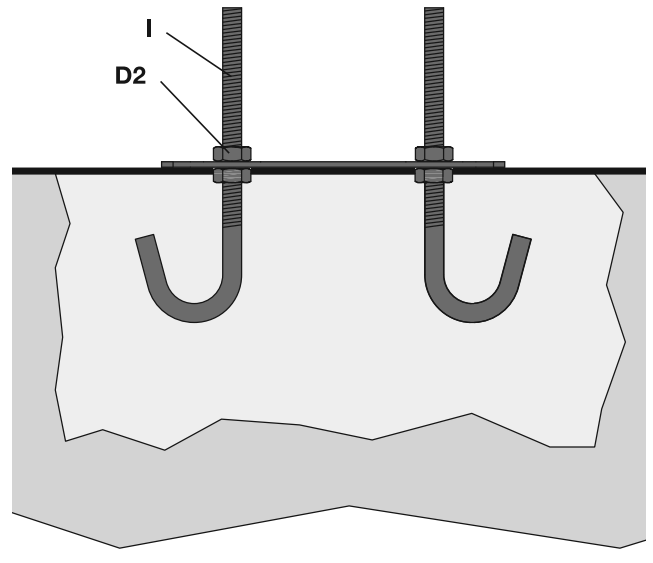

5

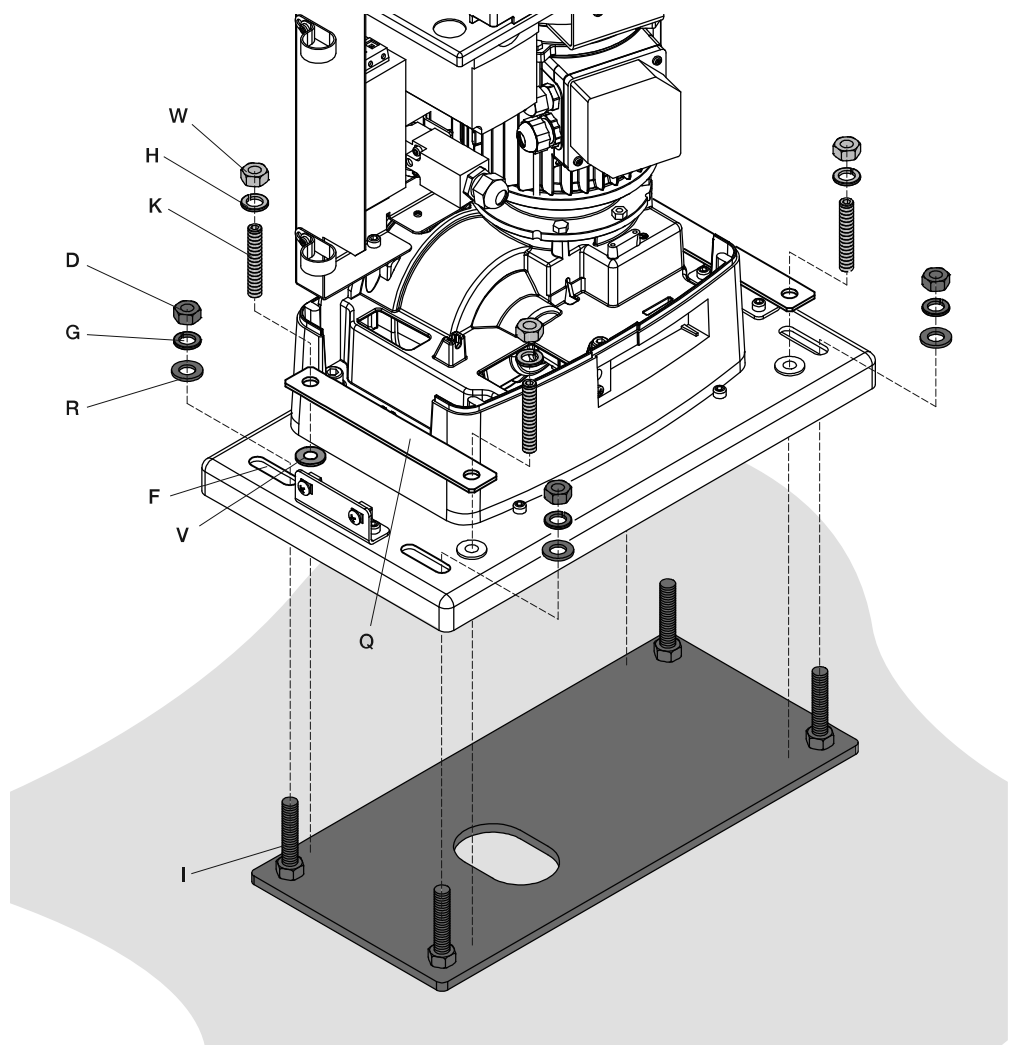

7

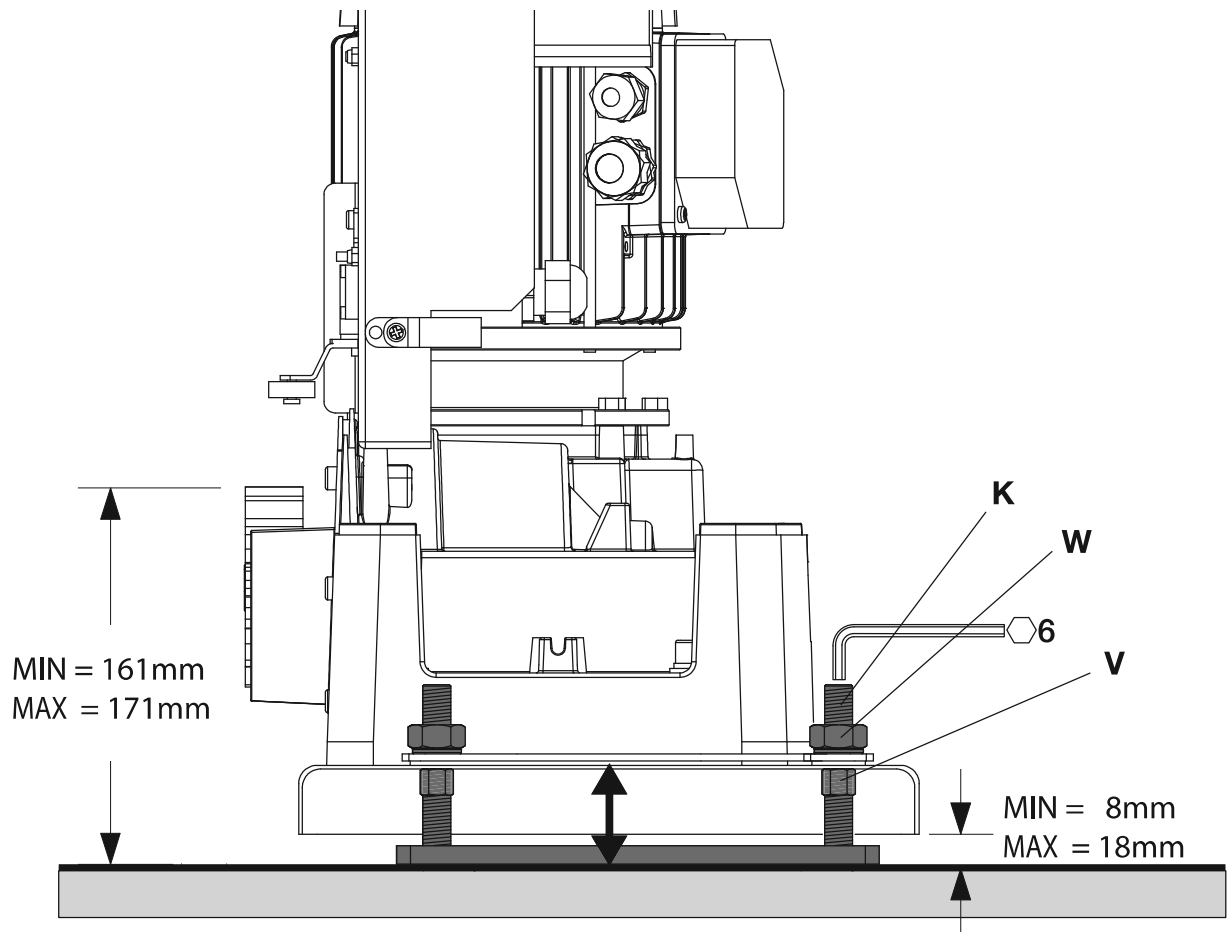

8

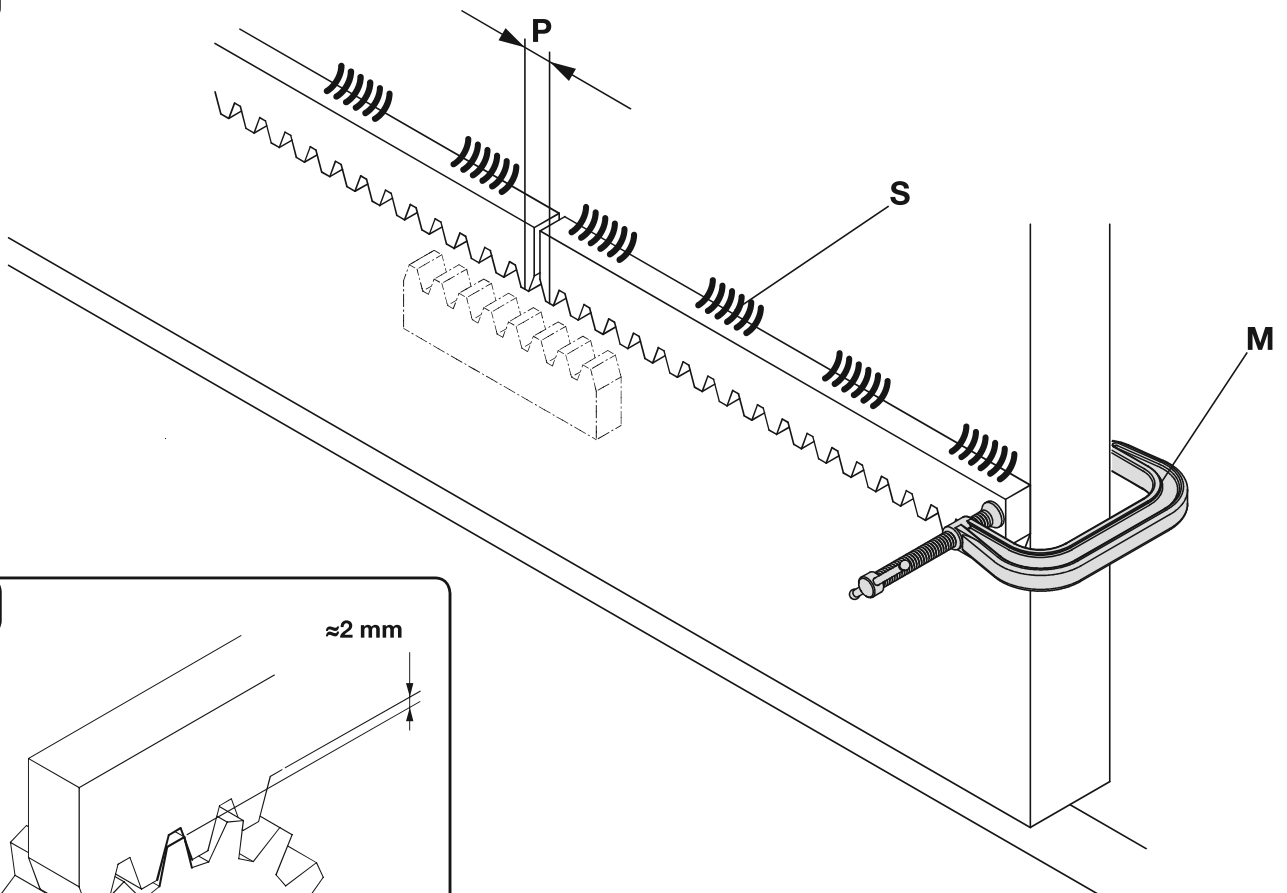

9

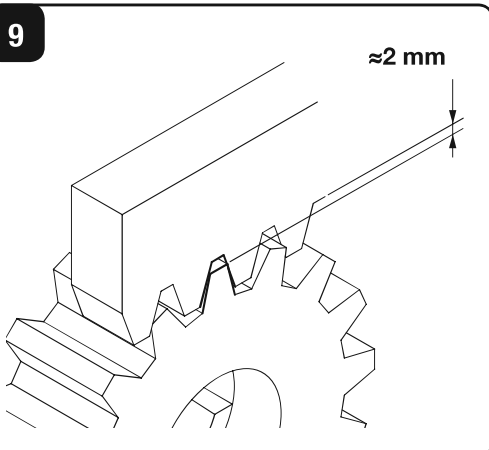

10

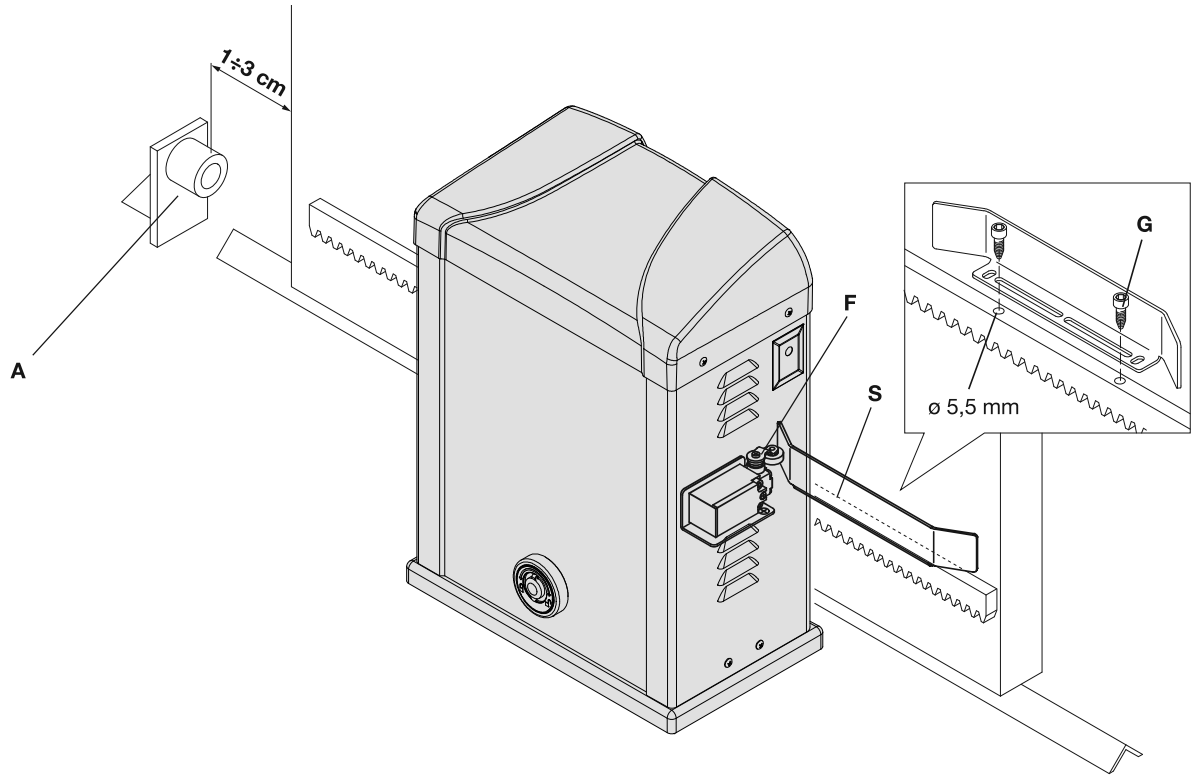

11

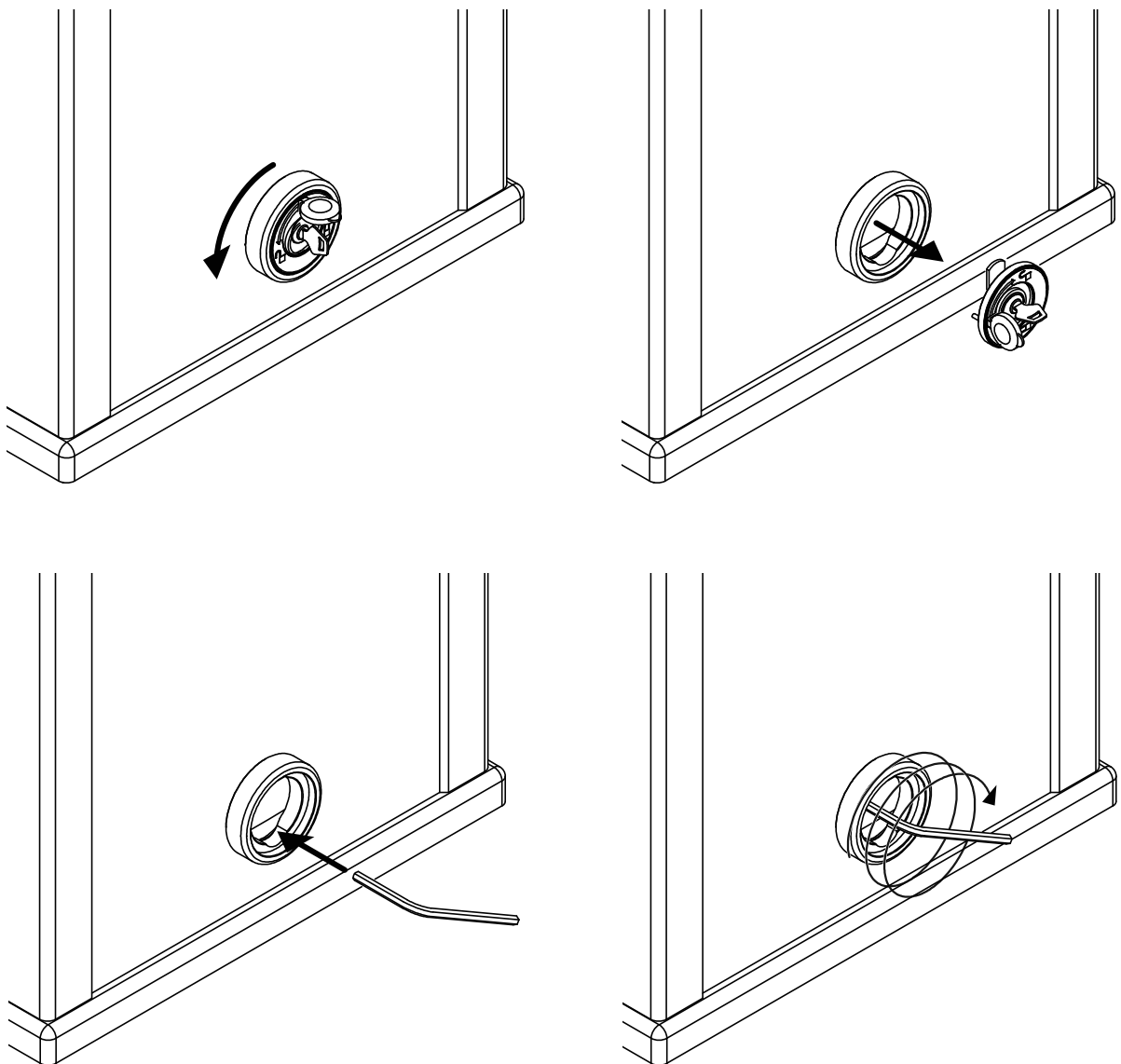

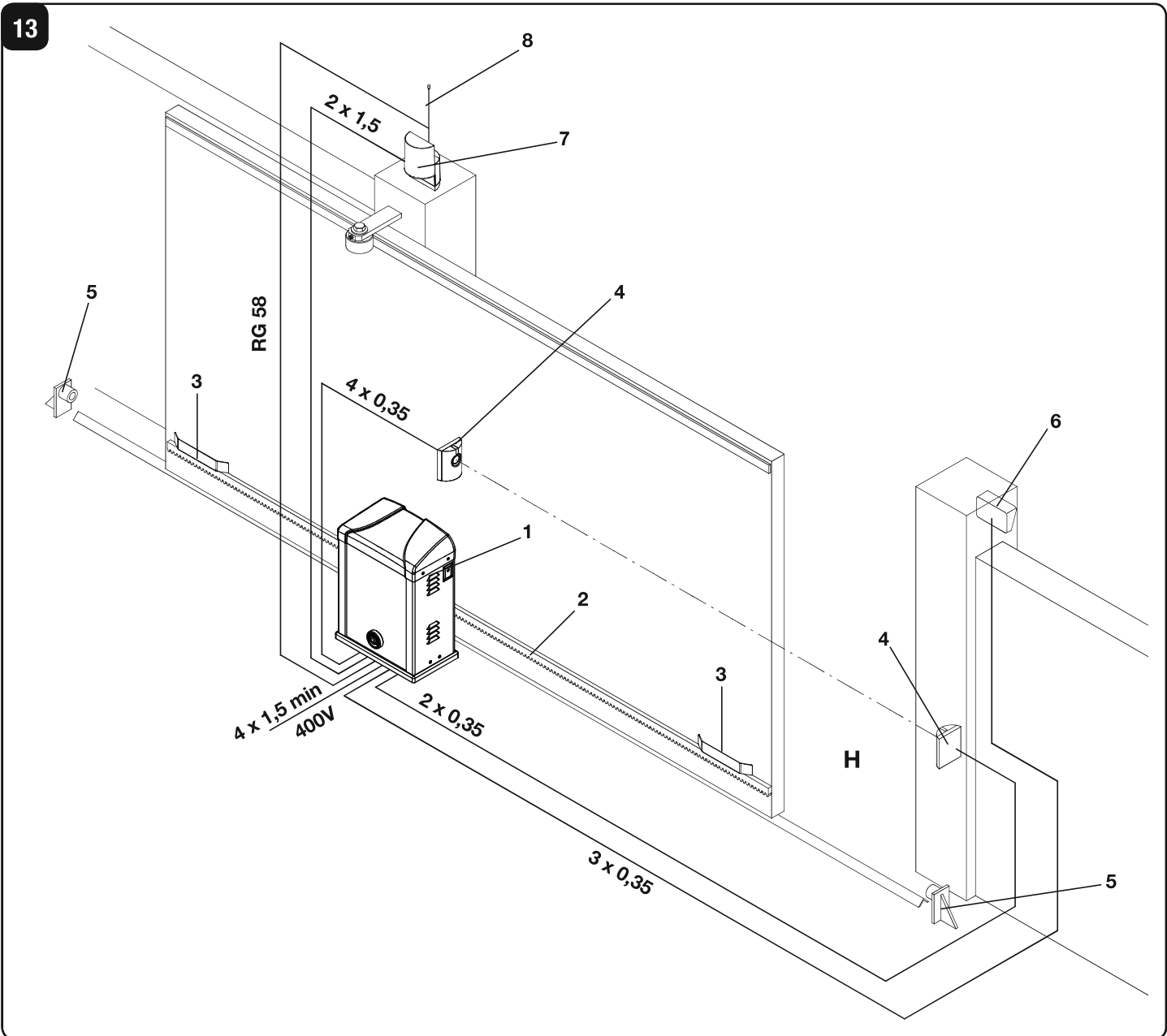
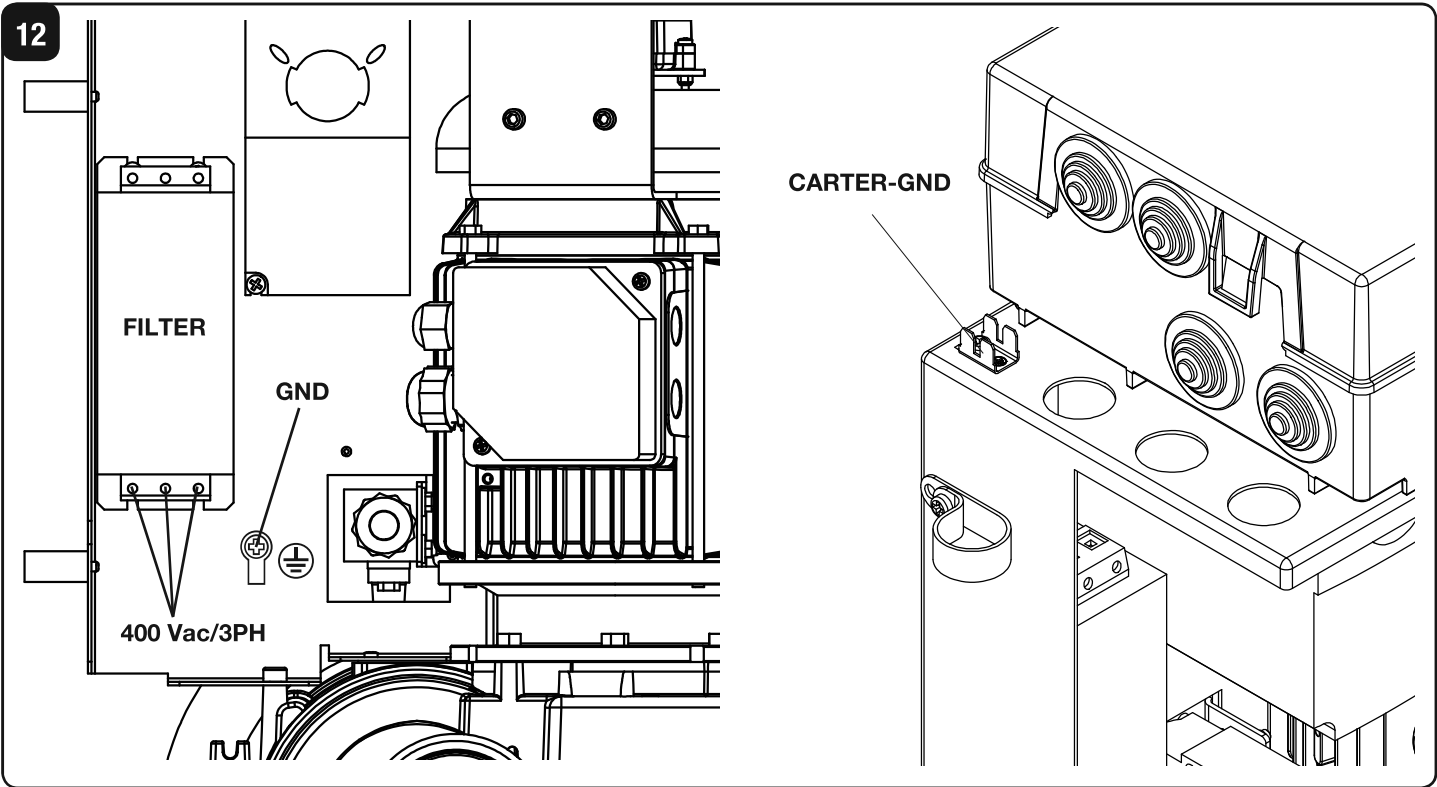

EC Declaration of Conformity

Directive 2004/108/EC(EMC); 2006/95/EC (LVD)

Manufacturer:

Automatismi Benincà SpA.

Address:

Via Capitello, 45 - 36066 Sandrigo (VI) – Italy

It is hereby stated that the product

automatic system 230 Vac for sliding gates

BISON 35 OTI

is compliant with provisions set forth in the following EC Directives:

- **DIRECTIVE 2004/108/EC OF THE EUROPEAN PARLIAMENT AND OF THE COUNCIL** of 15 December 2004, on the harmonisation of the laws of Member States relating to electromagnetic compatibility and which cancels Directive 89/336/EEC, according to the following harmonised regulations: EN 61000-6-2:2005, EN 61000-6-3:2007.

- **DIRECTIVE 2006/95/EC OF THE EUROPEAN PARLIAMENT AND OF THE COUNCIL** of 12 December 2006, on the harmonisation of the laws of Member States relating to electrical equipment designed for use with certain voltage limits, according to the following harmonised regulations: EN 60335-1:2002 + A1:2004 + A11:2004 + A12:2006 + A2:2006 + A13:2008; EN 60335-2-103:2003.

- **DIRECTIVE 2006/42/EC OF THE EUROPEAN PARLIAMENT AND OF THE COUNCIL** of 17 May 2006, on machinery, which amends Directive 95/16/EC, and complies with the requisites for the “partly completed machinery (almost machinery)” set forth in the EN13241-1:2003 regulation.

• Moreover, **Automatismi Benincà SpA** declares that the pertaining technical documentation has been drawn up in compliance with Attachment VII B of the 2006/42/ EC Directive and that the following requirements have been complied with: 1.1.1 - 1.1.2 - 1.1.3 - 1.1.5 - 1.2.1 - 1.2.3 - 1.2.6 - 1.3.1 - 1.3.2 - 1.3.3 - 1.3.4 - 1.3.7 - 1.3.9 - 1.5.1 - 1.5.2 - 1.5.4 - 1.5.5 - 1.5.6 - 1.5.7 - 1.5.8 - 1.5.10 - 1.5.11 - 1.5.13 - 1.6.1 - 1.6.2 - 1.6.4 - 1.7.2 - 1.7.4 - 1.7.4.1 - 1.7.4.2 - 1.7.4.3.

• The manufacturer undertakes that information on the “partly completed machinery” will be sent to domestic authorities. Transmission ways are also included in the undertaking, and the Manufacturer’s intellectual property rights of the “almost machinery” are respected.

• It is highlighted that commissioning of the “partly completed machinery” shall not be provided until the final machinery, in which it should be incorporated, is declared compliant, if applicable, with provisions set forth in the Directive 2006/42/EC on Machinery.

• Moreover, the product, as applicable, is compliant with the following regulations: EN 12445:2002, EN 12453:2002, EN 12978:2003.

Benincà Luigi, Legal Officer.

Sandrigo, 06/06/2012..

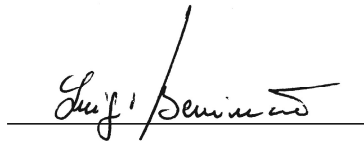

WARNING

The product shall not be used for purposes or in ways other than those for which the product is intended for and as described in this manual. Incorrect uses can damage the product and cause injuries and damages.

The company shall not be deemed responsible for the non-compliance with a good manufacture technique of gates as well as for any deformation, which might occur during use.

Keep this manual for further use.

Qualified personnel, in compliance with regulations in force, shall install the system.

Packaging must be kept out of reach of children, as it can be hazardous. For disposal, packaging must be divided the various types of waste (e.g. carton board, polystyrene) in compliance with regulations in force.

The installer must supply all information on the automatic, manual and emergency operation of the automatic system and supply the end user with instructions for use.



An omnipolar switch/section switch with remote contact opening equal to, or higher than 3mm must be provided on the power supply mains.. Make sure that before wiring an adequate differential switch and an overcurrent protection is provided.

Pursuant to safety regulations in force, some types of installation require that the gate connection be earthed.

During installation, maintenance and repair, cut off power supply before accessing to live parts.

Descriptions and figures in this manual are not binding. While leaving the essential characteristics of the product unchanged, the manufacturer reserves the right to modify the same under the technical, design or commercial point of view without necessarily update this manual.

INTRODUCTION

Congratulations on your choice of a **BISON** gear motor. All items included in Benincà's wide product range stem from twenty year of our experience in the sector of automatic systems, always striving to find new materials and advanced technologies.

For this reason, nowadays we are able to offer you extremely reliable products that, thanks to their power, efficiency and long-lasting features, entirely meet the end user's requirements.

All our products are covered by a guarantee. Furthermore, an R.C. insurance policy signed with a primary insurance company, covers any injuries or damages caused by manufacturing faults.

GENERAL INFORMATION

Automatic system with 400 VAC, three-phase power supply, for industrial use sliding gates of 3500 kg max weight.

BISON 35 OTI is equipped with:

- anti-crash electronic device (encoder)
- electronic braking.
- three-phase inverter.

SPECIFICATIONS

	BISON35 OTI
Mains power supply	Three-phase 380/480VAC 50/60Hz
Motor power supply	Three-phase 400VAC
Consumption	3A
Thrust	3000 N
Operating jogging	Intensive use
Protection level	IP44
Operating time	-20°C / +50°C
Gate max weight	3500 kg
Rack module	M6 Z 13
Opening speed	reg. 7-19 m/min
Noise	<70 dB
Lubrication	BISON OIL (0.3L)
Weight	57 kg

PRELIMINARY CHECKS

For a good operation of the automatic system for sliding gates, the gate/door to be automated shall feature the following characteristics:

- the guide track and related carriers should be adequately sized and subject to maintenance (in order to avert excessive friction during the gate sliding).
- during operation, no excessive oscillations should be reported to the gate/door.
- the opening and closing stroke should be limited to a mechanical stop (according to the current safety regulation).

These preliminary checks are **MANDATORY**. It is expressly **FORBIDDEN** to use the BISON automatic system on doors and gates not in good conditions or that have not undergone a correct maintenance.

INSTALLATION

OVERALL DIMENSIONS

Figure 1 shows the overall dimensions of the gear motor, expressed in mm.

Given the remarkable weight of the actuator, the device should be handled by at least 2 persons.

Loosen the 4 "A" screws (Fig. 1) and entirely remove the

front side of the system. Now all elements of the systems can be accessed.

If only the control unit is to be reached, it is sufficient to remove the 4 "B" screws by lifting the upper cover.

The niches for the photocell mounting (F) are provided on the motor removable side.

**Accessory plate BISON.P35
(cod. 9623066) NOT INCLUDED**

FOUNDATION PLATE - DIMENSIONS

The positioning dimensions of the foundation plate, expressed in millimeters, are shown in figure 2. The plate has one single hole for the passage of cable. While laying the flexible pipe, keep in mind that the hole must be positioned as indicated in Figure 2 (ref.C).

The plate should be positioned at 13mm from the floor (with possible adjustment +/- 5mm), 13 mm above floor-level usually avert any water stagnation.

At this height, the lower edge of the rack tooth should be at 156 mm.

If the rack is already installed, a fitting base, raised with respect to the floor, should be required. However, it is not advisable to lower the fitting surface.

If the rack used is the model RI.M6Z, the edge of the plate should lie perfectly parallel with respect to the door leaf and should be positioned at 70 mm. If a different rack is used, find the correct distance by temporarily fitting it to the door/gate leaf, then place the gear motor and check that the pinion and the rack are geared together.

INSTALLATION OF THE FOUNDATION PLATE

Provide for an adequate hole for the foundation.

Prepare the plate by fitting the foundation bolts, as shown in Fig. 3: Tighten the 4 D1 nuts to the foundation bolt T, then insert the plate and fix it with washers and the 4 D2 nuts.

Pour cement on the plate (Fig. 4), taking care that the plate level should lie perfectly flat. Check that the threaded inserts (I) for the fitting screws are clean and cement free.

Wait that the cement hardens, then remove the D2 nuts and R washers (Fig. 5), remove the plate, reinsert the D2 nuts and washers and then replace the plate.

Note: It is also possible to use highly resistant special dowels to fix the foundation plate onto the floor. In this case, make sure that there is no water stagnation.

In any case, the foundation plate should be adequate to the stress exercised on the automatic system.

HOW TO FIT THE GEAR MOTOR

Place the gear motor on the foundation plate, as indicated in Figure 5, by inserting the cables "I" in the special slots "F". Introduce the 4 grub screws M12x70 "K" in the four threaded holes V. The grub screws must lay on the foundation plate. The gear motor can be lifted from the foundation plate by using the gains K.

Before locking the grub screws K, by using the washer H and nuts W, insert the blocking plates Q, as indicated in Figure 5. The plates Q are **ESSENTIAL** to ensure the gear motor stability on the supporting plate.

Fix the gear motor to the base, by using the washers R, the threaded washers G and nuts D.

The threaded holes allow for the horizontal movement of the gear motor, which is required to gear/ungear the pinion to the rack.

HOW TO ADJUST THE GEAR MOTOR HEIGHT

As indicated in the previous paragraph, height is adjusted by using grub screws K which are placed on the plate.

Should the gear motor height must be adjusted, proceed as follows:

- back-off nuts D
- back-off nuts W
- adjust the 4 grub screws K by using a 6mm hexagon key.
- once the correct height of the geared motor is obtained, fix nuts W and D again.

Do not raise the plate for more than 18 mm in order not to exercise excessive stress onto the foundation bolts (Fig.7).

HOW TO FIT THE RACK

Temporarily fit the rack by using clamps, for example. Check that the system is perfectly flat, then fit the rack to the gate with various welding points of by using adequate screws.

Keep to the tooth pitch P, even from the rack spaces. To this purpose, it might be useful to match another piece of rack (Fig. 8 - Detail C).

Lastly fix the rack with screws V, making sure that, once the actuator is installed, around 2 mm backlash is left between the rack and the drive wheel (see Fig. 9).

HOW TO POSITION THE LIMIT SWITCH BRACKETS

Manually open the gate, leaving 1 – 3 cm space, according to the weight of the gate, between the gate/door and the mechanical stopper A (Fig. 10).

Then fix the bracket of the limit switch S in order that the micro-switch F of the limit switch is kept pressed.

After drilling two holes of \varnothing 5.5mm, use the two screws G supplied.

Repeat this operation with closed gate/door.

NOTE: The limit switch bracket should be positioned in order to allow that the gate/door stops its movement without hitting the mechanical stopper.

MANUAL OPERATION

In the event of power failure or faults, the gate can be manually operated as follows (Fig.11):

- Open the protective cap from the lock, introduce the customized key supplied and turn it by 90° anti-clockwise.
- Remove the lock group, introduce the hexagonal key supplied, and repeatedly turn clockwise the system until it reaches its limit switches.
- The gear motor is released and the gate can be manually opened or closed.
- To reset the normal operation, introduce the hexagonal key once again, and turn it repeatedly anti-clockwise, until it stops.
- Apply the lock group again, making sure that the anti-rotation pin be introduced in the hole on the gear group.
- Turn the key clockwise, then remove it and close the protection cap again.

CONNECTION TO GROUND (EARTH)

As regards the **COMPULSORY** earthing, a special Faston 4-pin connector fitted onto the central support (Fig. 12 – CARTER-GND) is supplied. Ground connections of the upper removable side and the lower side can be connected to this Faston.

To allow an easy removal of the sides, they are not supplied pre-cabled to the connector. The installer shall provide for their connection, by using the already equipped with Faston terminal.

As shown in Figure 12, mains power supply should be connected to the mains filter (Fig. 12-FILTER), while for grounding the special terminal should be in use (Fig. 12-GND).

WIRE DIAGRAM

Figure 13 shows the cables to the preset for the installation of the gear motor and the main accessories.

As regards the wire connection of the automatic system and the adjustment of the operating modes, see the instruction manual of the control unit.

Namely, the calibration of the anti-crash device sensitivity (encoder) should be carried out in compliance with regulations in force.

Before introducing the cables, check the type of cabling required for the accessories actually used.

Key of components:

- 1 Gear motor with BISON built-in control unit.
- 2 Rack
- 3 Limit switch brackets
- 4 Photocells
- 5 Mechanical stoppers
- 6 Key selector or digital keypad
- 7 Flashing light
- 8 Antenna

Note: The removable side of the BISON gear motor comes already preset for the mounting of the FTC.S photocells.

WARNING

The RC product insurance policy, which covers any injuries or damages to objects caused by manufacturing defects, requires the use of Benincà's original accessories.

SAFETY MEASURES

- Do not stand within the gate movement area.
- Children must not play with controls and near the gate.
- In the event of malfunctions, do not attempt to repair the failure but contact the specialised personnel.

MANUAL OPERATION

In the event of power failure or faults, the gate can be manually operated as follows (Fig.1):

- Open the protective cap from the lock, introduce the customized key supplied and turn it by 90° anti-clockwise.
- Remove the lock group, introduce the hexagonal key supplied, and repeatedly turn clockwise the system until it reaches its limit switches.
- The gear motor is released and the gate can be manually opened or closed.
- To reset the normal operation, introduce the hexagonal key once again, and turn it repeatedly anti-clockwise, until it stops.
- Apply the lock group again, making sure that the anti-rotation pin be introduced in the hole on the gear group.
- Turn the key clockwise, then remove it and close the protection cap again.

MAINTENANCE

- Every month check the good operation of the emergency manual release.
- It is mandatory not to carry out extraordinary maintenance or repairs as accidents may be caused. These operations must be carried out by qualified personnel only.
- The operator is maintenance free but it is necessary to check periodically if the safety devices and the other components of the automation system work properly. Wear and tear of some components could cause dangers.

WASTE DISPOSAL



As indicated by the symbol shown, it is forbidden to dispose this product as normal urban waste as some parts might be harmful for environment and human health, if they are disposed of incorrectly. Therefore, the device should be disposed in special collection platforms or given back to the reseller if a new and similar device is purchased. An incorrect disposal of the device will result in fines applied to the user, as provided for by regulations in force.

WARNING

All Benincá products are covered by insurance policy for any possible damages to objects and persons caused by construction faults under condition that the entire system be marked CE and only Benincá parts be used.

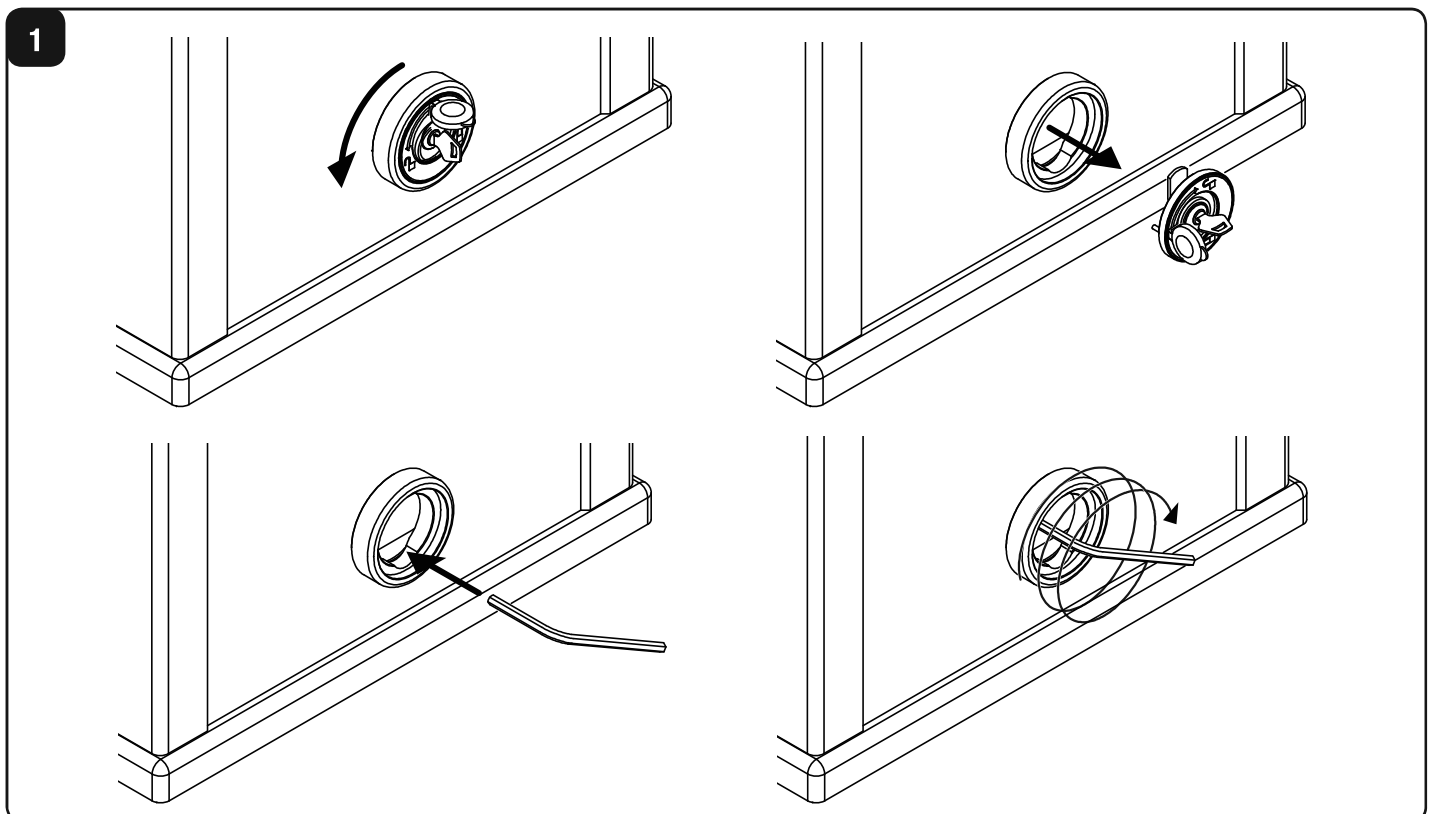

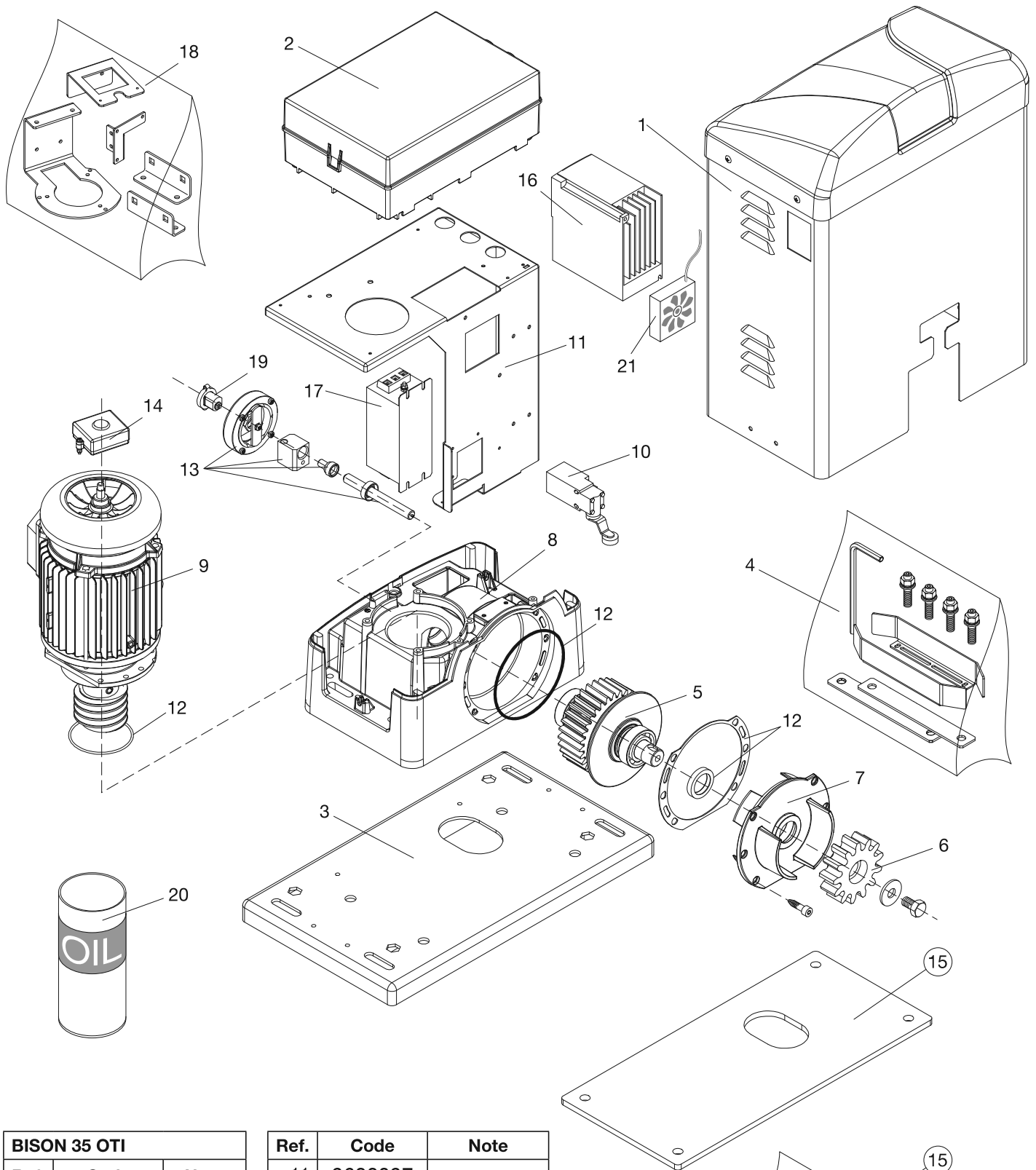

BISON 35 OTI		
Ref.	Code	Note
1	9688093	
2	9686549	
3	9688094	
4	9688209	
5	9688108	
6	9686048	
7	9686335	
8	9688105	
9	9688096	
10	9686663	

Ref.	Code	Note
11	9688097	
12	9686694	
13	9688098	
14	9760021	MAG.E
15	9623066	BISON.P35
16	9688099	
17	9686698	
18	9688100	
19	9686980	
20	9688109	5 L
21	9688127	

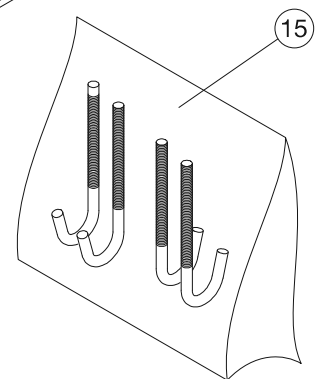

BENINCA[®]

AUTOMATISMI BENINCÀ SpA - Via Capitello, 45 - 36066 Sandrigo (VI) - Tel. 0444 751030 r.a. - Fax 0444 759728
